

特維
MARGARET SW

GENERAL ARRANGEMENT

SCALE : 1/200

PRINCIPAL PARTICULARS

LENGTH O. A.	157.23 m
LENGTH B. P.	150.60 m
BREADTH (MLD)	26.80 m
DEPTH (MLD)	13.20 m
FULL LOAD DRAGT (SUMMER EXT.)	9.114 m
GROSS TONNAGE	15,861 t
DEAD WEIGHT (DESIGNED DRAFT)	25,010mt
MAIN ENGINE	MAN-B&W 6S42MC (MK6)
M. C. O.	5,850 kW x 129 min ⁻¹
C. S. O. (85% M.C.O.)	4,972 kW x 122 min ⁻¹
SERVICE SPEED	
(C.S.O. with 15% S.M. at DESIGNED DRAFT)	abt. 14.00kts
COMPLEMENT	24 p

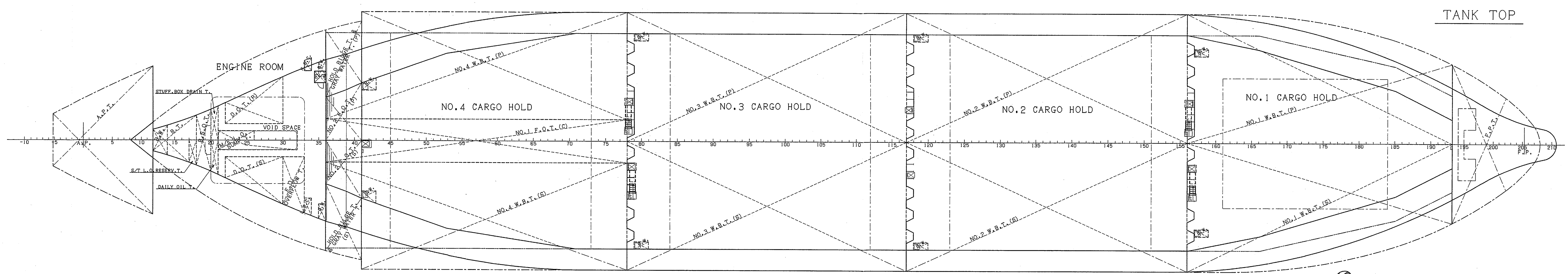
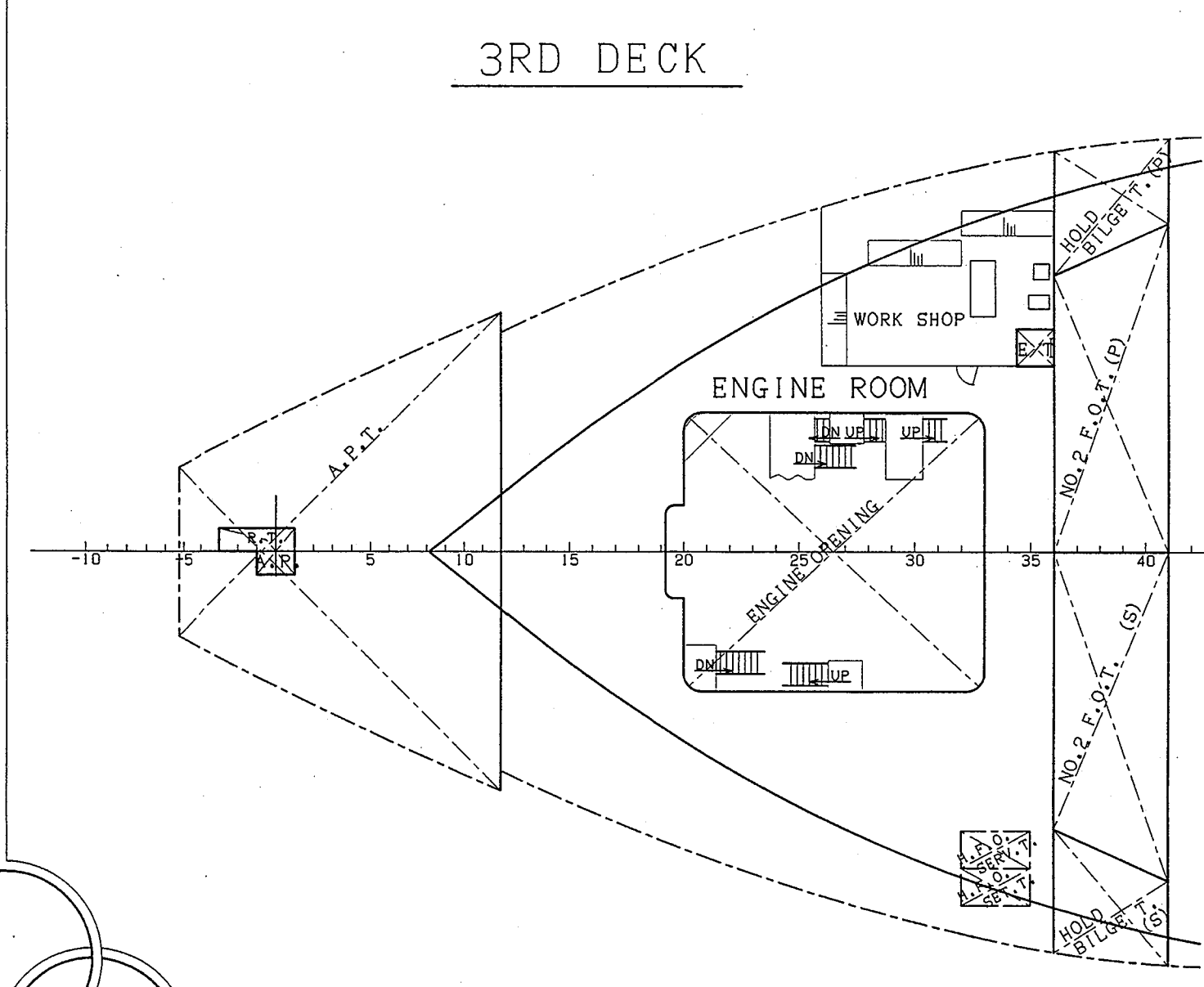
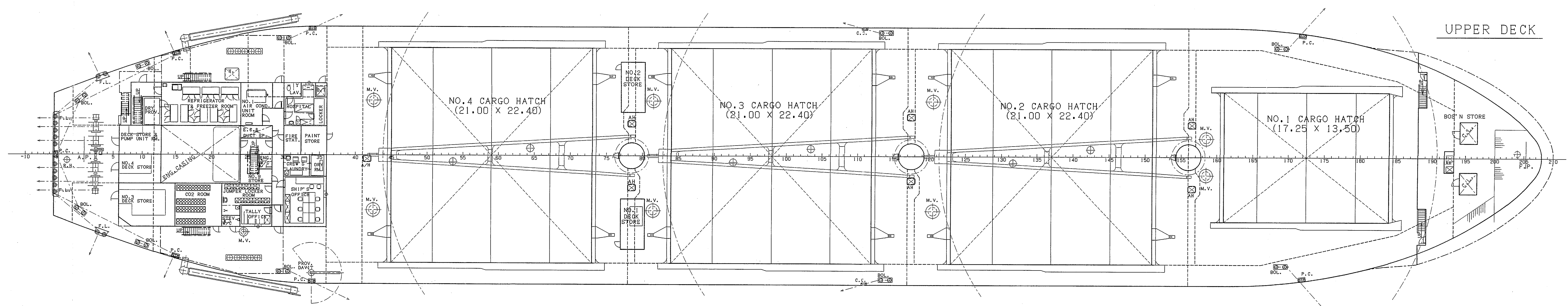
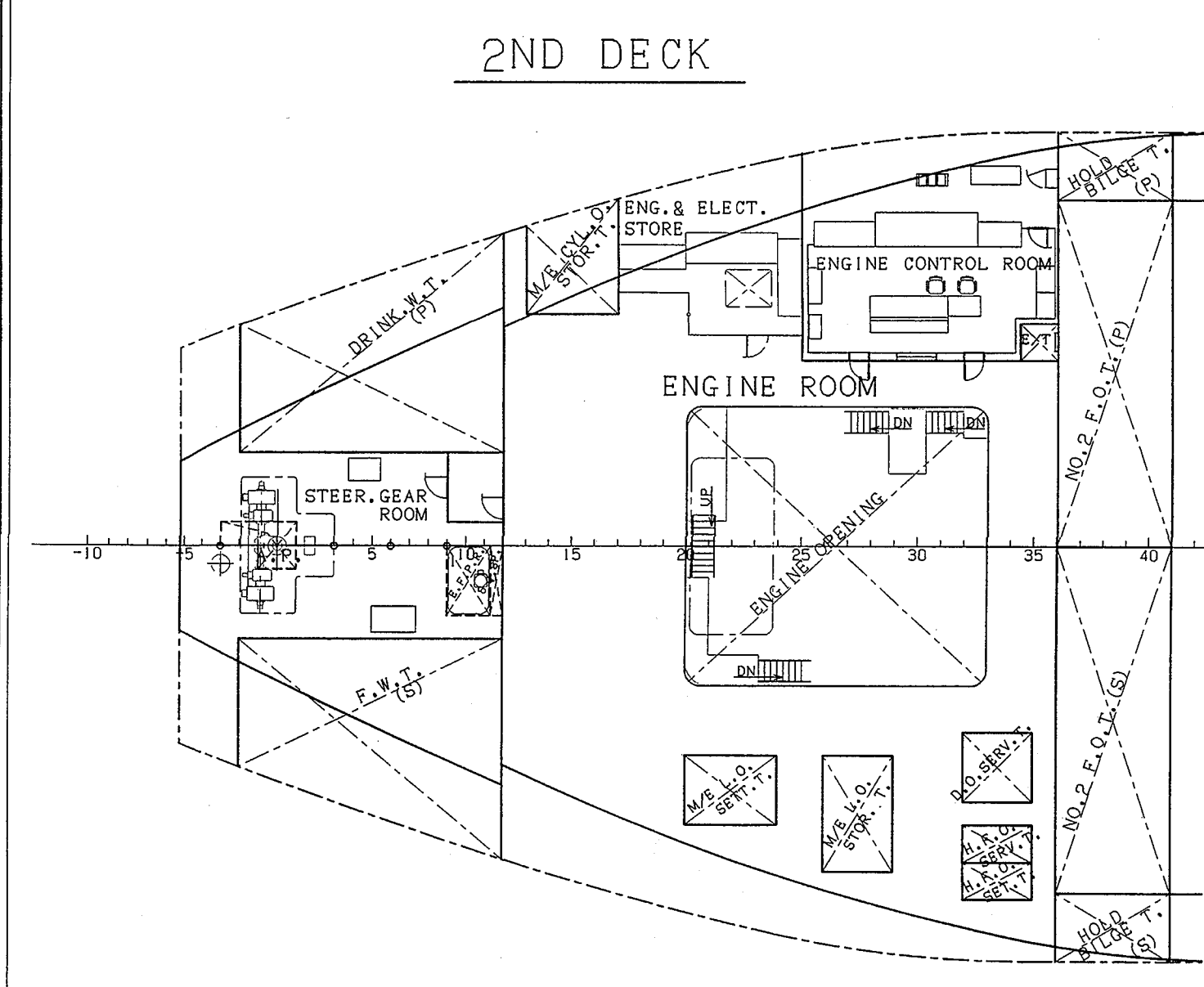
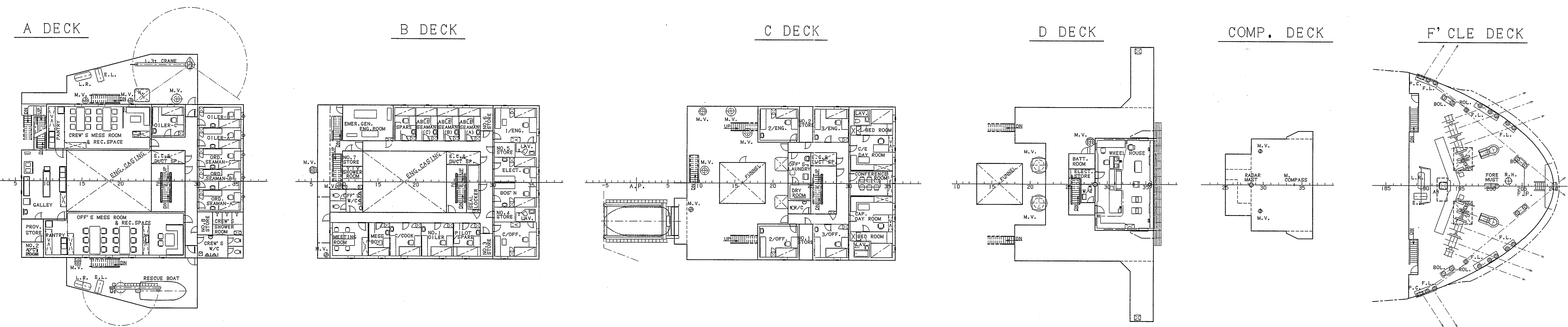
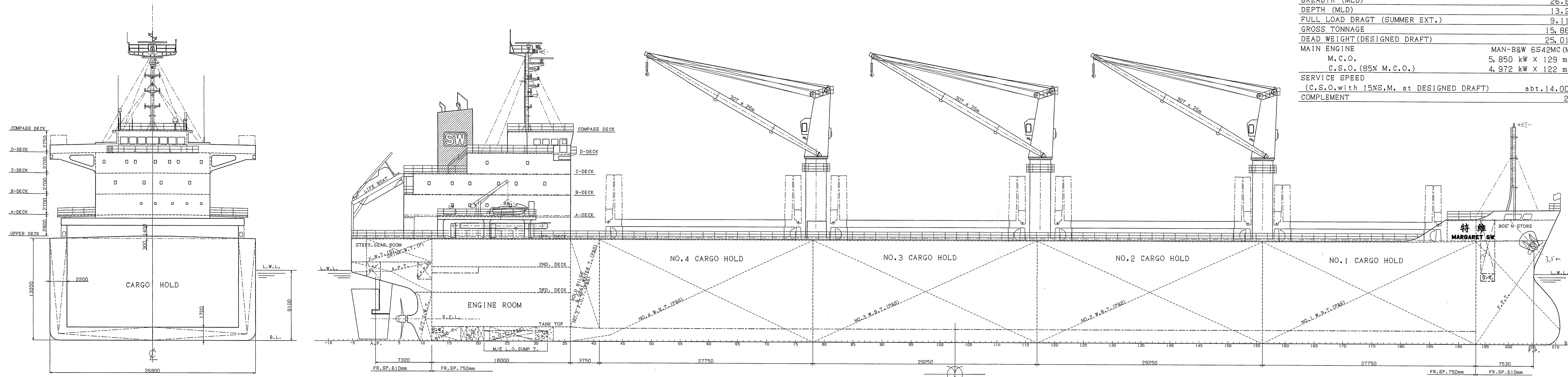

YAMANISHI CORPORATION

BIBLIOGRAPHY

12th MARCH 2012
Prepared for finished plan.

MANAGER K. Nagahara	SHIP NO. 1071	DRAWING NO. B-110	CLASS N K
ASS. MANAGER H. Homma	D.W.24.00M.T. TYPE BULK CARRIER		
CHIEF M. Shimizu	GENERAL ARRANGEMENT		
ASS. CHIEF M. Shimizu	FINISHED PLAN		
CHECKED J. Anzaki	DATE 12th Mar. '12		
DATE 12th Mar. '12	SCALE 1: 200		

YAMANISHI CORPORATION

MAR